



Standard electric actuator for 1/4 turn valve

Popis

400V 3 phase : please contact us Overall dimensions : See product sheet Many options available, please contact us

#	()	()	ISO 5211 ()	(N.m)	(s)	()
1	ER10	100-240 VAC / 100-350 VDC	F03-F04-F05 / 14	10	11	66
2	ER20	100-240 VAC / 100-350 VDC	F05 / 14	20	12	66
3	ER35	100-240 VAC / 100-350 VDC	F05-F07 / 22	35	7	66
4	ER60	100-240 VAC / 100-350 VDC	F05-F07 / 22	60	12	66
5	ER100	100-240 VAC / 100-350 VDC	F05-F07 / 22	100	23	66
6	VS150	100-240 VAC / 100-350 VDC	F07-F10 / 22	125	30	68
7	VS300	100-240 VAC / 100-350 VDC	F07-F10 / 22	250	60	68
8	VT600	100-240 VAC / 100-350 VDC	F10-F12 / 36	450	38	68
9	VT1000	100-240 VAC / 100-350 VDC	F10-F12 / 36	750	38	68
10	VT1500	100-240 VAC / 100-350 VDC	F12-F16 / 46	1200	113	68
11	ER10	15-30 VAC / 12-48 VDC	F03-F04-F05 / 14	10	11	66
12	ER20	15-30 VAC / 12-48 VDC	F05 / 14	20	12	66
13	ER35	15-30 VAC / 12-48 VDC	F05-F07 / 22	35	7	66
14	ER60	15-30 VAC / 12-48 VDC	F05-F07 / 22	60	12	66
15	ER100	15-30 VAC / 12-48 VDC	F05-F07 / 22	100	23	66
16	VS150	15-30 VAC / 12-48 VDC	F07-F10 / 22	125	30	68
17	VS300	15-30 VAC / 12-48 VDC	F07-F10 / 22	250	60	68

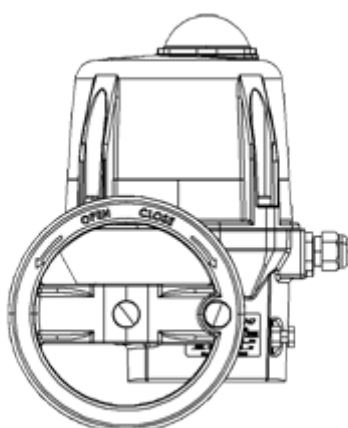

Technické údaje o produktech nejsou závazné. Konstrukční a rozměrové změny vyhrazeny.
Přeloženo z originálu výrobce.

Farprosys, s.r.o.
email: info@farprosys.com
tel. +420 728 757 770
www.atexventilatory.cz