

Volume control dampers standard continuous adjustment with servomotor PN

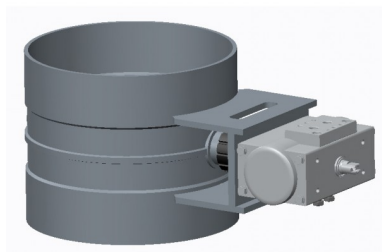

Popis

with servomotor PN, for pneumatic operation

PVC

#	d	L	L1	L2	H1	H2	s	kg
1	0050	130	35	60	103	37	3,0	0,6
2	0063	130	35	60	110	44	3,0	0,7
3	0075	130	35	60	116	50	3,0	0,8
4	0090	130	35	60	123	57	3,0	0,8
5	0110	150	40	70	133	67	3,0	0,9
6	0125	150	40	70	141	81	3,0	1,0
7	0140	150	40	70	148	88	3,0	1,0
8	0160	150	40	70	158	98	3,0	1,1
9	0180	170	50	70	168	108	3,0	1,2
10	0200	170	50	70	178	118	3,0	1,3
11	0225	170	50	70	191	131	3,0	1,4
12	0250	170	50	70	203	145	3,0	1,5
13	0280	170	50	70	218	160	3,0	1,8
14	0315	175	50	75	236	178	3,0	2,2
15	0355	175	50	75	258	213	4,0	2,1
16	0400	200	60	80	281	235	4,0	2,6

PPs

#	d	L	L1	L2	H1	H2	s	kg
1	0050	130	35	60	103	37	3,0	0,6
2	0063	130	35	60	110	44	3,0	0,7
3	0075	130	35	60	116	50	3,0	0,7
4	0090	130	35	60	123	57	3,0	0,7
5	0110	150	40	70	133	67	3,0	0,8
6	0125	150	40	70	141	81	3,0	0,8
7	0140	150	40	70	148	88	3,0	0,9
8	0160	150	40	70	158	98	3,0	0,9
9	0180	170	50	70	168	108	3,0	1,0
10	0200	170	50	70	178	118	3,0	1,1
11	0225	170	50	70	191	131	3,0	1,1
12	0250	170	50	70	203	145	3,0	1,3
13	0280	170	50	70	218	160	3,0	1,4
14	0315	175	50	75	236	178	3,0	1,6
15	0355	175	50	75	258	213	4,0	1,5
16	0400	180	50	80	281	235	4,0	1,9

PP

#	d	L	L1	L2	H1	H2	s	kg
1	0050	130	35	60	103	37	3,0	0,6
2	0063	130	35	60	110	44	3,0	0,7
3	0075	130	35	60	116	50	3,0	0,7
4	0090	130	35	60	123	57	3,0	0,7
5	0110	150	40	70	133	67	3,0	0,8
6	0125	150	40	70	141	81	3,0	0,8
7	0140	150	40	70	148	88	3,0	0,9
8	0160	150	40	70	158	98	3,0	0,9
9	0180	170	50	70	168	108	3,0	1,0
10	0200	170	50	70	178	118	3,0	1,1
11	0225	170	50	70	191	131	3,0	1,1
12	0250	170	50	70	203	145	3,0	1,3
13	0280	170	50	70	218	160	3,0	1,4
14	0315	175	50	75	236	178	3,0	1,6
15	0355	175	50	75	258	213	4,0	1,5
16	0400	180	50	80	281	235	4,0	1,9

PE

#	d	L	L1	L2	H1	H2	s	kg
1	0050	130	35	60	103	37	3,0	0,6
2	0063	130	35	60	110	44	3,0	0,7
3	0075	130	35	60	116	50	3,0	0,7
4	0090	130	35	60	123	57	3,0	0,7
5	0110	150	40	70	133	67	3,0	0,8
6	0125	150	40	70	141	81	3,0	0,8
7	0140	150	40	70	148	88	3,0	0,9
8	0160	150	40	70	158	98	3,0	0,9
9	0180	170	50	70	168	108	3,0	1,0
10	0200	170	50	70	178	118	3,0	1,1
11	0225	170	50	70	191	131	3,0	1,1
12	0250	170	50	70	203	145	3,0	1,3
13	0280	170	50	70	218	160	3,0	1,4
14	0315	175	50	75	236	178	3,0	1,6
15	0355	175	50	75	258	213	4,0	1,5
16	0400	180	50	80	281	235	4,0	1,9

PPs-el

#	d	L	L1	L2	H1	H2	s	kg
1	0050	130	35	60	103	37	3,0	0,6
2	0063	130	35	60	110	44	3,0	0,7
3	0075	130	35	60	116	50	3,0	0,7
4	0090	130	35	60	123	57	3,0	0,7
5	0110	150	40	70	133	67	3,0	0,8
6	0125	150	40	70	141	81	3,0	0,8
7	0140	150	40	70	148	88	3,0	0,9
8	0160	150	40	70	158	98	3,0	0,9
9	0180	170	50	70	168	108	3,0	1,0
10	0200	170	50	70	178	118	3,0	1,1
11	0225	170	50	70	191	131	3,0	1,1
12	0250	170	50	70	203	145	3,0	1,3
13	0280	170	50	70	218	160	3,0	1,4
14	0315	175	50	75	236	178	3,0	1,6
15	0355	175	50	75	258	213	4,0	1,5
16	0400	180	50	80	281	235	4,0	1,9

PVDF

#	d	L	L1	L2	H1	H2	s	kg
1	0050	130	35	60	103	37	3,0	0,6
2	0063	130	35	60	110	44	3,0	0,7
3	0075	130	35	60	116	50	3,0	0,7
4	0090	130	35	60	123	57	3,0	0,7
5	0110	150	40	70	133	67	3,0	0,8
6	0125	150	40	70	141	81	3,0	0,8
7	0140	150	40	70	148	88	3,0	0,9
8	0160	150	40	70	158	98	3,0	0,9
9	0180	170	50	70	168	108	3,0	1,0
10	0200	170	50	70	178	118	3,0	1,1
11	0225	170	50	70	191	131	3,0	1,1
12	0250	170	50	70	203	145	3,0	1,3
13	0280	170	50	70	218	160	3,0	1,4
14	0315	175	50	75	236	178	3,0	1,6
15	0355	175	50	75	258	213	4,0	1,5
16	0400	180	50	80	281	235	4,0	1,9

PVC-UV

#	d	L	L1	L2	H1	H2	s	kg
1	0050	130	35	60	103	37	3,0	0,6
2	0063	130	35	60	110	44	3,0	0,7
3	0075	130	35	60	116	50	3,0	0,8
4	0090	130	35	60	123	57	3,0	0,8
5	0110	150	40	70	133	67	3,0	0,9
6	0125	150	40	70	141	81	3,0	1,0
7	0140	150	40	70	148	88	3,0	1,0
8	0160	150	40	70	158	98	3,0	1,1
9	0180	170	50	70	168	108	3,0	1,2
10	0200	170	50	70	178	118	3,0	1,3
11	0225	170	50	70	191	131	3,0	1,4
12	0250	170	50	70	203	145	3,0	1,5
13	0280	170	50	70	218	160	3,0	1,8
14	0315	175	50	75	236	178	3,0	2,2
15	0355	175	50	75	258	213	4,0	2,1
16	0400	200	60	80	281	235	4,0	2,6

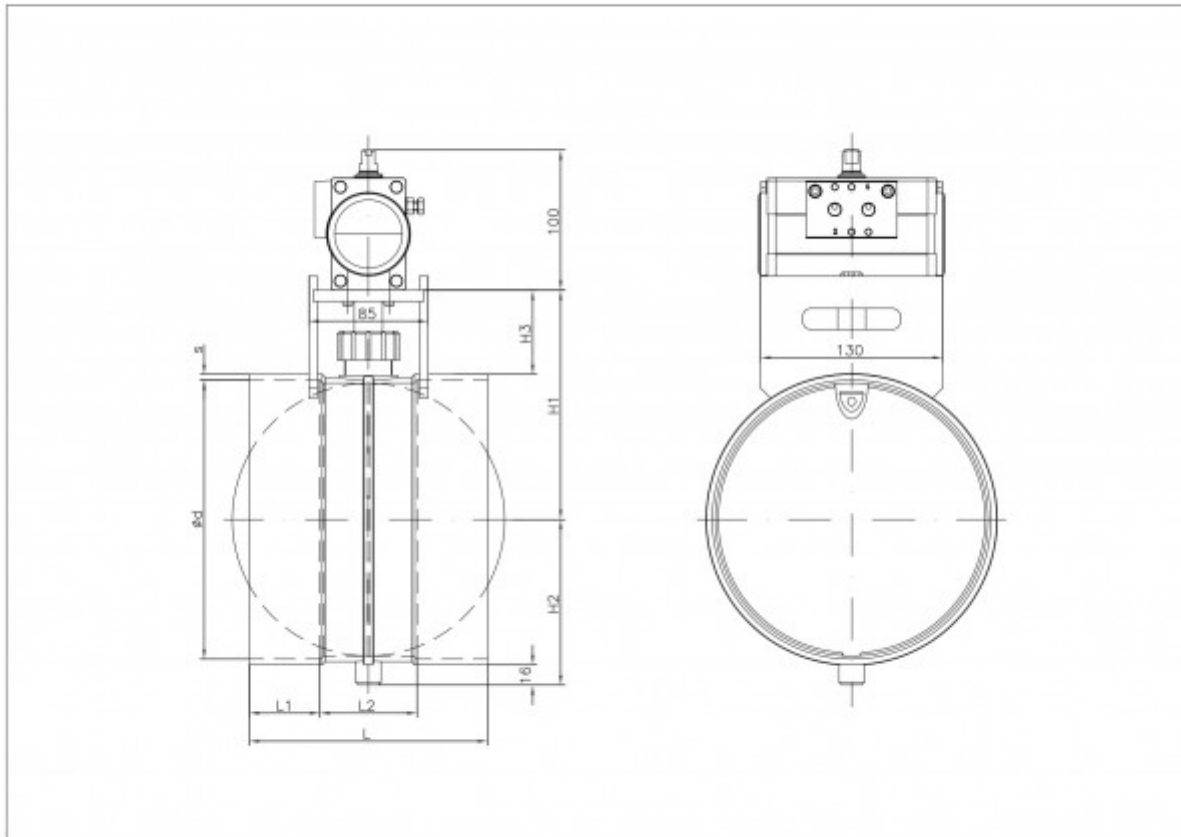

Technické údaje o produktech nejsou závazné. Konstrukční a rozměrové změny vyhrazeny.
Přeloženo z originálu výrobce.

Farprosys, s.r.o.
email: info@farprosys.com
tel. +420 728 757 770
www.atexventilatory.cz